



SMARTLAB
PCI BUS 16 CHANNELS PHOTO
ISOLATOR INPUT/OUTPUT
ADAPTER

OPERATION MANUAL



Decision Computer Int'l. Co., Ltd.



CHAPTER 1
INTRODUCTION

The PCI 16 channels photo isolator input/output adapter is a 32 bits PCI bus board with Plug and Play (PnP) features, it is a programmable I/O interface card for PC/486, Pentium, or compatibles. The PnP features let hardware configuration for IRQ and I/O address is detected by BIOS automatically, you don't need set switch and jumper.

The PCI 16 channels photo isolator input/output adapter provides 16 photo couple digital input/output channels, which allow the input/output signals to be completely floated and prevent the ground loop.

❖ The features of PCI 16 channels photo isolator input/output adapter are:

- 32 bits PCI bus with Plug and Play (PnP) features.
- Support 16 photo couple input/output channels.
- Allow the photo input/output signals to be completely floated and prevent the ground loops.
- 16 LED correspond to 16 output ports activation status.
- By using PC817 photo couple chips.
- 5000V isolation voltage.
- Maximum load voltage is 30V.
- Maximum 50mA forward input current.
- Output voltage : $V_{cd} = 35V$, $V_{ec} = 6V$, and maximum collector current is 50mA. (Maximum current restrict below 30mA.)



- Voltage range from 0V to 30V, where 0 to 4V is OFF and 5V to 30V is ON.
- Operating temperature range from 0 to 33C.
- Relative humidity range from 0 to 90%.

❖ **PACKAGE CONTENTS:**

- SMARTLAB PCI bus 16 channels photo couple input/output adapter.
- One flat cable.
- User's manual.
- Warranty form.

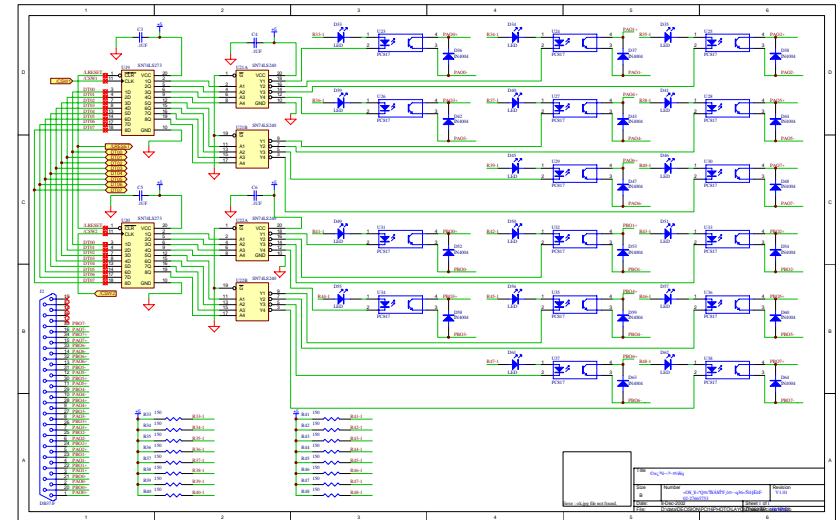
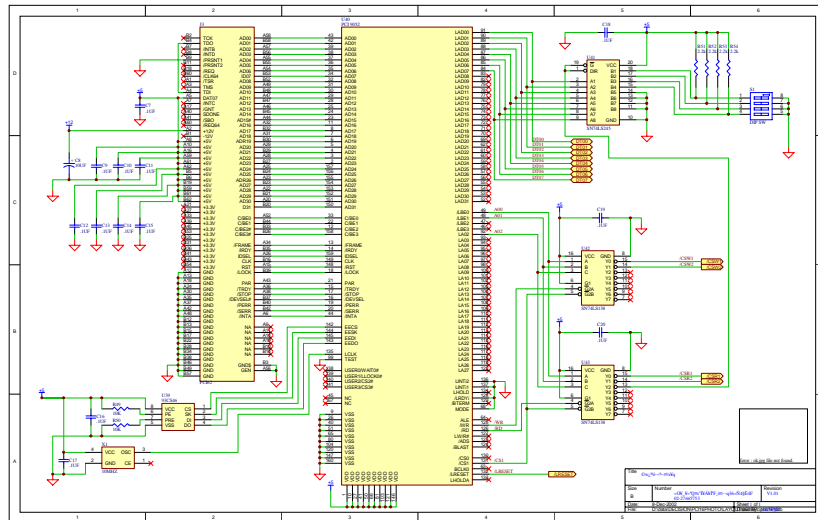

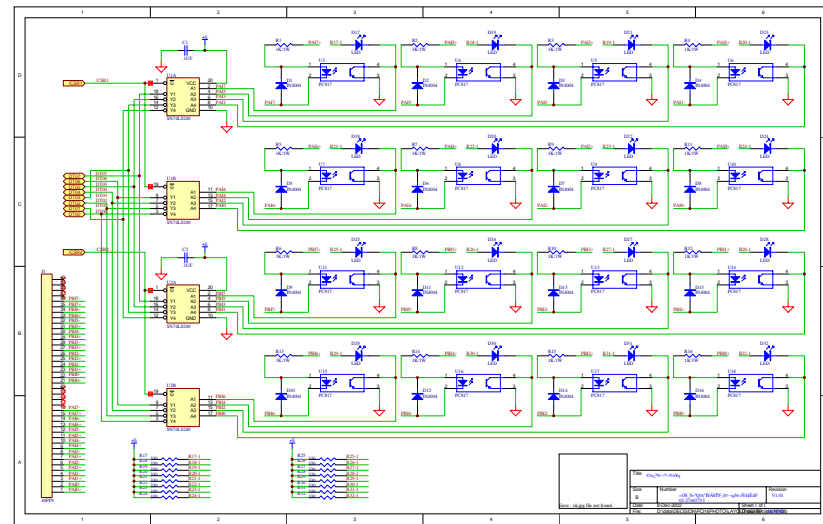

CHAPTER 2

HARDWARE INSTALLATION

Your PCI bus 16 channels photo isolator input/output adapter is designed to be inserted in any available PCI slot in your PC/486, Pentium or compatibles. In order to gain access to the expansion slots, follow the steps listed below:

1. Turn off all power to your computer and all peripheral devices before installing your 16 channels photo isolator input/output adapter.
2. Remove the cover of the computer.
3. Insert the 16 channels photo isolator input/output adapter into any available PCI slot. Make sure the adapter is firmly seated in the chosen slot.
4. Replace the cover of the computer.
5. Turn on the power of your computer, the PnP features will recognize the 16 channels photo isolator input/output adapter.





CHAPTER 3

HARDWARE CONFIGURATION

Before you use the PCI 16 channels photo couple input/output adapter, Please check our technical web site <http://www.smatlab.com>. You must ensure that the I/O address after boot your computer. Observe the figure in the follows, the proper jumper settings for the 16 channels photo couple input/output adapter is described in the following.

3.1 Switch Settings

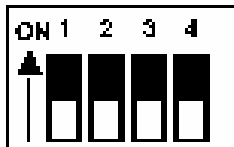

- Card No 1 : All OFF
- Card No 2 : 1 ON, 2, 3, 4 OFF
- Card No 3 : 2 ON, 1, 3, 4 OFF
- Card No 4 : 3 ON, 1, 2, 4 OFF

The switch is used to identify card number. Please set card number by card identifier switch, the PCI BIOS will assign pre-allocated I/O address to each adapter. Please set different card number to each adapter (do not duplicate card number setting).

3.2 I/O Address

The PnP feature will get base I/O address automatically, where



Base Address + 0:

Photo isolator output channel 1 to 16

15	14	13	12	11	10	9	8
PBO7	PBO6	PBO5	PBO4	PBO3	OPBO2	PB1	PBO0

7	6	5	4	3	2	1	0
PAO7	PAO6	PAO5	PAO4	PAO3	PAO2	PAO1	PAO0

Base Address + 0:

Photo isolator input channel 1 to 16.

15	14	13	12	11	10	9	8
PBI7	PBI6	PBI5	PBI4	PBI3	PBI2	PBI1	PBI0

7	6	5	4	3	2	1	0
PAI7	PAI6	PAI5	PAI4	PAI3	PAI2	PAI1	PAI0

3.3 Connector Assignments

1. DB 37/M Connector Pin Assignments (J2)

The photo isolator output signal is assigned in the DB37/M (J2) connector, its pin assignments are show in the below.

Pin	Single	Description
1	PAO-01+	Opto-isolator Ch. 01 + Output
2	PAO -01-	Opto-isolator Ch. 01 - Output
3	PAO -02+	Opto-isolator Ch. 02 + Output
4	PAO -02-	Opto-isolator Ch. 02 - Output
5	PAO -03+	Opto-isolator Ch. 03 + Output
6	PAO -03-	Opto-isolator Ch. 03 - Output
7	PAO -04+	Opto-isolator Ch. 04 + Output
8	PAO -04-	Opto-isolator Ch. 04 - Output
9	PAO -05+	Opto-isolator Ch. 05 + Output
10	PAO -05-	Opto-isolator Ch. 05 - Output
11	PAO -06+	Opto-isolator Ch. 06 + Output
12	PAO -06-	Opto-isolator Ch. 06 - Output
13	PAO -07+	Opto-isolator Ch. 07 + Output
14	PAO -07-	Opto-isolator Ch. 07 - Output
15	PAO -08+	Opto-isolator Ch. 08 + Output
16	PAO -08-	Opto-isolator Ch. 08 - Output
17	NC	
18	NC	
19	NC	
20	PBO-01+	Opto-isolator Ch. 09 + Output
21	PBO -01-	Opto-isolator Ch. 09 - Output
22	PBO -02+	Opto-isolator Ch. 10 + Output
23	PBO -02-	Opto-isolator Ch. 10 - Output
24	PBO -03+	Opto-isolator Ch. 11 + Output
25	PBO -03-	Opto-isolator Ch. 11 - Output
26	PBO -04+	Opto-isolator Ch. 12 + Output
27	PBO -04-	Opto-isolator Ch. 12 - Output
28	PBO -05+	Opto-isolator Ch. 13 + Output

29	PBO -05-	Opto-isolator Ch. 13 - Output
30	PBO -06+	Opto-isolator Ch. 14 + Output
31	PBO -06-	Opto-isolator Ch. 14 - Output
32	PBO -07+	Opto-isolator Ch. 15 + Output
33	PBO -07-	Opto-isolator Ch. 15 - Output
34	PBO -08+	Opto-isolator Ch. 16 + Output
35	PBO -08-	Opto-isolator Ch. 16 - Output
36	NC	
37	NC	

2. Flat Cable

There is one flat cable that contains one 40-pin connector at one side, and one DB37 connector at another side. The flat cable can be connected to DB37 (J2) connector to let user use 40-pin signal directly. The pin assignments of 40-pin on the flat cable are show in the below.

Pin	Single	Description
1	PAO-01+	Opto-isolator Ch. 01 + Output
3	PAO -01-	Opto-isolator Ch. 01 - Output
5	PAO -02+	Opto-isolator Ch. 02 + Output
7	PAO -02-	Opto-isolator Ch. 02 - Output
9	PAO -03+	Opto-isolator Ch. 03 + Output
11	PAO -03-	Opto-isolator Ch. 03 - Output
13	PAO -04+	Opto-isolator Ch. 04 + Output
15	PAO -04-	Opto-isolator Ch. 04 - Output
17	PAO -05+	Opto-isolator Ch. 05 + Output
19	PAO -05-	Opto-isolator Ch. 05 - Output
21	PAO -06+	Opto-isolator Ch. 06 + Output
23	PAO -06-	Opto-isolator Ch. 06 - Output
25	PAO -07+	Opto-isolator Ch. 07 + Output
27	PAO -07-	Opto-isolator Ch. 07 - Output
29	PAO -08+	Opto-isolator Ch. 08 + Output
31	PAO -08-	Opto-isolator Ch. 08 - Output
33	NC	



35	NC	
37	NC	
2	PBO-01+	Opto-isolator Ch. 09 + Output
4	PBO -01-	Opto-isolator Ch. 09 - Output
6	PBO -02+	Opto-isolator Ch. 10 + Output
8	PBO -02-	Opto-isolator Ch. 10 - Output
10	PBO -03+	Opto-isolator Ch. 11 + Output
12	PBO -03-	Opto-isolator Ch. 11 - Output
14	PBO -04+	Opto-isolator Ch. 12 + Output
16	PBO -04-	Opto-isolator Ch. 12 - Output
18	PBO -05+	Opto-isolator Ch. 13 + Output
20	PBO -05-	Opto-isolator Ch. 13 - Output
22	PBO -06+	Opto-isolator Ch. 14 + Output
24	PBO -06-	Opto-isolator Ch. 14 - Output
26	PBO -07+	Opto-isolator Ch. 15 + Output
28	PBO -07-	Opto-isolator Ch. 15 - Output
30	PBO -08+	Opto-isolator Ch. 16 + Output
32	PBO -08-	Opto-isolator Ch. 16 - Output
34	NC	
36	NC	



3. 40-PIN Connector Pin Assignments (J1)

The photo isolator input signal is assigned in 40 pin (J1) connector, its pin assignments are show in the below.

Pin	Single	Description
1	PAI-01+	Opto-isolator Ch. 01 + Input
3	PAI -01-	Opto-isolator Ch. 01 - Input
5	PAI -02+	Opto-isolator Ch. 02 + Input
7	PAI -02-	Opto-isolator Ch. 02 - Input
9	PAI -03+	Opto-isolator Ch. 03 + Input
11	PAI -03-	Opto-isolator Ch. 03 - Input
13	PAI -04+	Opto-isolator Ch. 04 + Input
15	PAI -04-	Opto-isolator Ch. 04 - Input
17	PAI -05+	Opto-isolator Ch. 05 + Input
19	PAI -05-	Opto-isolator Ch. 05 - Input
21	PAI -06+	Opto-isolator Ch. 06 + Input
23	PAI -06-	Opto-isolator Ch. 06 - Input
25	PAI -07+	Opto-isolator Ch. 07 + Input
27	PAI -07-	Opto-isolator Ch. 07 - Input
29	PAI -08+	Opto-isolator Ch. 08 + Input
31	PAI -08-	Opto-isolator Ch. 08 - Input
33	NC	
35	NC	
37	NC	
2	NC	
4	PBI-01+	Opto-isolator Ch. 09 + Input
6	PBI -01-	Opto-isolator Ch. 09 - Input
8	PBI -02+	Opto-isolator Ch. 10 + Input
10	PBI -02-	Opto-isolator Ch. 10 - Input
12	PBI -03+	Opto-isolator Ch. 11 + Input
14	PBI -03-	Opto-isolator Ch. 11 - Input
16	PBI -04+	Opto-isolator Ch. 12 + Input
18	PBI -04-	Opto-isolator Ch. 12 - Input
20	PBI -05+	Opto-isolator Ch. 13 + Input
22	PBI -05-	Opto-isolator Ch. 13 - Input





24	PBI -06+	Opto-isolator Ch. 14 + Input
26	PBI -06-	Opto-isolator Ch. 14 - Input
28	PBI -07+	Opto-isolator Ch. 15 + Input
30	PBI -07-	Opto-isolator Ch. 15 - Input
32	PBI -08+	Opto-isolator Ch. 16 + Input
34	PBI -08-	Opto-isolator Ch. 16 - Input
36	NC	
	NC	
	NC	
	NC	

4. Flat Cable

There is one flat cable that contains one 40-pin connector at one side, and one DB37 connector at another side. The flat cable can be connected to 40-pin (J1) connector to let user use DB37 signal directly. The pin assignments of DB37 on the flat cable are show in the below.

Pin	Single	Description
1	PAI-01+	Opto-isolator Ch. 01 + Input
2	PAI -01-	Opto-isolator Ch. 01 - Input
3	PAI -02+	Opto-isolator Ch. 02 + Input
4	PAI -02-	Opto-isolator Ch. 02 - Input
5	PAI -03+	Opto-isolator Ch. 03 + Input
6	PAI -03-	Opto-isolator Ch. 03 - Input
7	PAI -04+	Opto-isolator Ch. 04 + Input
8	PAI -04-	Opto-isolator Ch. 04 - Input
9	PAI -05+	Opto-isolator Ch. 05 + Input
10	PAI -05-	Opto-isolator Ch. 05 - Input
11	PAI -06+	Opto-isolator Ch. 06 + Input
12	PAI -06-	Opto-isolator Ch. 06 - Input
13	PAI -07+	Opto-isolator Ch. 07 + Input
14	PAI -07-	Opto-isolator Ch. 07 - Input
15	PAI -08+	Opto-isolator Ch. 08 + Input
16	PAI -08-	Opto-isolator Ch. 08 - Input



17	NC	
18	NC	
19	NC	
20	NC	
21	PBI-01+	Opto-isolator Ch. 09 + Input
22	PBI -01-	Opto-isolator Ch. 09 - Input
23	PBI -02+	Opto-isolator Ch. 10 + Input
24	PBI -02-	Opto-isolator Ch. 10 - Input
25	PBI -03+	Opto-isolator Ch. 11 + Input
26	PBI -03-	Opto-isolator Ch. 11 - Input
27	PBI -04+	Opto-isolator Ch. 12 + Input
28	PBI -04-	Opto-isolator Ch. 12 - Input
29	PBI -05+	Opto-isolator Ch. 13 + Input
30	PBI -05-	Opto-isolator Ch. 13 - Input
31	PBI -06+	Opto-isolator Ch. 14 + Input
32	PBI -06-	Opto-isolator Ch. 14 - Input
33	PBI -07+	Opto-isolator Ch. 15 + Input
34	PBI -07-	Opto-isolator Ch. 15 - Input
35	PBI -08+	Opto-isolator Ch. 16 + Input
36	PBI -08-	Opto-isolator Ch. 16 - Input
37	NC	

3.4 Loopback Diagnostic

To test your 16 channel photo isolator input/output card, we recommend you use loopback circuit shown in below. Where IA*+ means input channel+ and IA*- means input channel-, OA*+ means output channel+ and OA*- means output channel-. * means channel number. Please note that, if you use IA2+, you must connect its pair IA2-otherwise it may short the circuit.

In this experiment, if VCC larger than 10V, then it input HIGH to input channel, otherwise it input LOW; your program can get this digital signal easily. If no VCC voltage input, the output channel will be loopback to input channel, it means when output HIGH then input channel get HIGH, when output LOW then input channel get LOW.

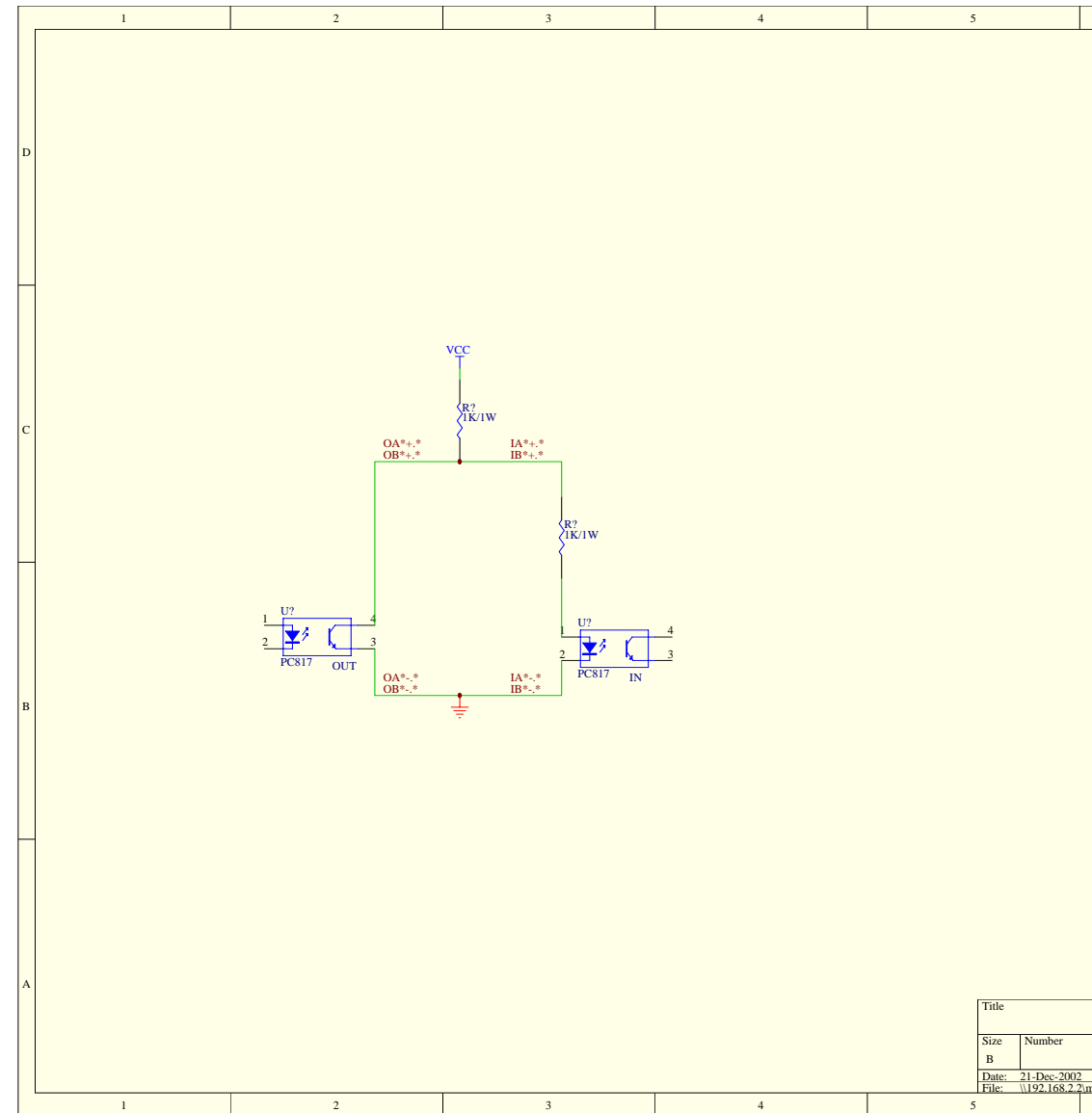

Title	
Size	Number
B	
Date:	21-Dec-2002
File:	\192.168.2.2\min



APPENDIX A

WARRANTY INFORMATION

A.1 Copyright

Copyright DECISION COMPUTER INTERNATIONAL CO., LTD. All rights reserved. No part of SmartLab software and manual may be produced, transmitted, transcribed, or translated into any language or computer language, in any form or by any means, electronic, mechanical, magnetic, optical, chemical, manual, or otherwise, without the prior written permission of DECISION COMPUTER INTERNATIONAL CO., LTD.

Each piece of SmartLab package permits user to use SmartLab only on a single computer, a registered user may use he program on a different computer, but may not use the program on more than one computer at the same time.

Corporate licensing agreements allow duplication and distribution of specific number of copies within the licensed institution. Duplication of multiple copies is not allowed except through execution of a licensing agreement. Welcome call for details.



A.2 Warranty Information

SmartLab warrants that for a period of one year from the date of purchase (unless otherwise specified in the warranty card) that the goods supplied will perform according to the specifications defined in the user manual. Furthermore that the SmartLab product will be supplied free from defects in materials and workmanship and be fully functional under normal usage.

In the event of the failure of a SmartLab product within the specified warranty period, SmartLab will, at its option, replace or repair the item at no additional charge. This limited warranty does not cover damage resulting from incorrect use, electrical interference, accident, or modification of the product.

All goods returned for warranty repair must have the serial number intact. Goods without serial numbers attached will not be covered by the warranty.

The purchaser must pay transportation costs for goods returned. Repaired goods will be dispatched at the expense of SmartLab.

To ensure that your SmartLab product is covered by the warranty provisions, it is necessary that you return the Warranty card.

Under this Limited Warranty, SmartLab's obligations will be limited to repair or replacement only, of goods found to be defective a specified above during the warranty period. SmartLab is not liable to the purchaser for any damages or losses of any kind, through the use of, or inability to use, the



SmartLab product.

SmartLab reserves the right to determine what constitutes warranty repair or replacement.

Return Authorization: It is necessary that any returned goods are clearly marked with an RA number that has been issued by SmartLab. Goods returned without this authorization will not be attended to.

APPENDIX B

DATA SHEET

